

EXPLODING BALLOON WALL

Set up the Matrix

The flexible framework for the wall is a Rouse Octagon-Square Aperture (ROSA) Matrix by Rouse International of Columbia, South Carolina. The framework is a 28" grid with 4 columns of 3 balloons in each column of large, octagon shaped openings. Hence, the designation (ROSA 28" - 4x3).

1. Place a ground cover approximately 2' wide by 9.5' long on the ground where you plan to install the exploding wall. (We recommend carpet with vertical fibers to allow any grit to sink below where the carpet will contact the balloons used in the wall.)

2. Layout Matrix on top of the ground cover. Initially, the Matrix will be considerably longer than the ground cover, but the Matrix will shorten to approximately 9.5' when fully loaded with balloons.

3. Attach adjacent tabs on the upper edge to each other as shown to the right.

4. Attach the tabs on the lower edge to each other as shown to the right.

5. Attach the upper left hand tab of the Matrix to a support with the end approximately 7 feet above ground.

6. Attach the upper right hand tab of the Matrix to a support with the end approximately 7 feet above ground.

7. Separate the two upper ends of the Matrix by approximately 9.5 feet. (The object is to keep the upper edge of the Matrix fairly straight and about 7' above ground. The Matrix should hang open with 12 large openings and six smaller ones between the larger ones as shown to the right, below.)

Prepare Balloons

8. Draw a line around the center of each of 12 uninflated 3' balloons. This line should be perpendicular to the axis through the inflation neck of the balloon (as shown below).

9. Inflate (12) 24" balloons to approximately 20" in diameter. Tie each balloon individually, close to the body of the balloon. Leave as long an uninflated neck as you can.

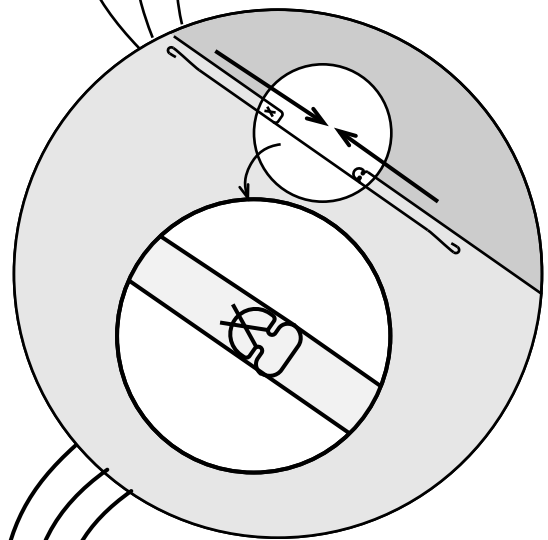
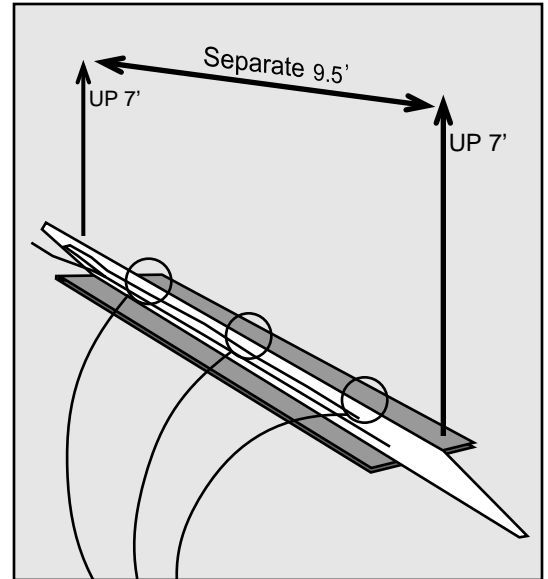
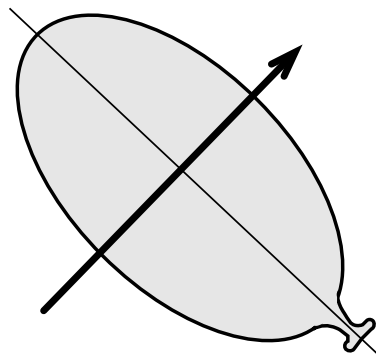

Insert the tab head from the lower right into the "X" slot of the tab from the upper left so that the two pieces interlock. There are three such tab sets on the upper edge of the Matrix as indicated by the circles.

There are three more such tab sets on the lower edge of the Matrix. Connect the lower three sets in the same way.

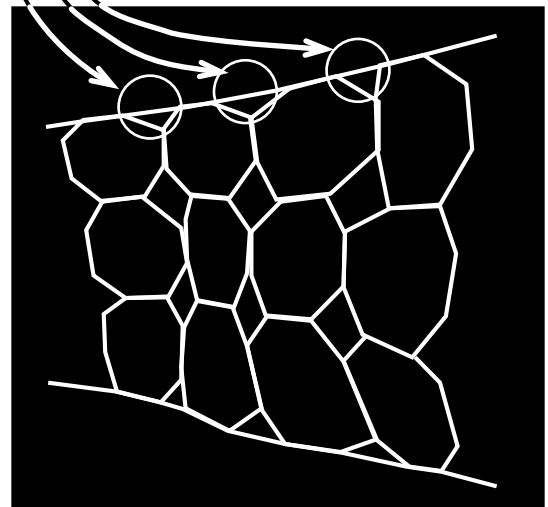

EXPLODING BALLOON WALL

Install 3' Balloons

10. Place a 3' balloon in one of the two center apertures on the bottom row of the hanging Matrix. Inflate to approximately 30" in diameter. This should be a gentle fit in the surrounding Matrix strap. The fit will tighten later as surrounding balloons are inflated. The strap around the balloon should line up with the line drawn on the balloon before inflation. The neck of the balloon should be to the rear (away from the audience) of the balloon wall you are building. Tape each balloon to the framework at the "corners" (upper left & right, lower left & right).

11. Continue inserting, inflating and taping 3' balloons in the sequence as numbered in the illustration to the upper right. Other sequences can work, so feel free to experiment if you like, but we have found this pattern effective and recommend it.

Install the 24" Balloons

12. Pass the neck of one 24" balloon through one of the small apertures between 3' balloons and tie it to the neck of a second 24" balloon on the other side of the balloon wall. Tie the two balloons as close together as you can. **Note** the upper right hand corner of the illustration to the right. You can see through the 3' balloon and see how one of the 24" balloons is on the back side of the Matrix while the other 24" balloon of the pair is on the front side of the balloon wall.

13. Repeat at the other 5 openings between 3' balloons.

Change the Supports for the Balloon Wall

14. Attach a support line from a stable structure on one end of the balloon wall to the knotted end of the first two 3' balloons on the top row. (That will be on the back side of the wall away from the audience.)

15. Attach a support line from a stable structure at the other end of the balloon wall to the knotted end of the last two 3' balloons on the top row. (**DO NOT** put a line connecting the middle two balloons of the top row!)

16. Disconnect the original support line used to lift the Matrix into position. Your finished set up should look very much like the illustration to the lower right.

Attach Your Explosion System to the Balloons

17. Run your wires or tubes along the back side of the balloon wall and attach to the balloons according to instruction for your explosion system. Then follow the firing instructions on cue for a **BIG BANG!!!**

TIPS

A. The balloon wall tends to jump toward the audience when it explodes. Set the wall back from the front edge of any stage or ledge to prevent it from falling over the edge.

B. Tie a line to the Matrix and to the ground cover along the floor from the side with the lead wires/tubes for your explosion system. This way you can quickly pull the Matrix and your system off stage, out of view, and into your hands for safe keeping and possible reuse.

C. For added excitement you might include confetti in the top row of balloons or even place confetti cannons between some of the 3' balloons to fire at the same time, or immediately before the balloons.

D. For more information visit this web site:

www.rouseinternational.com

